

MOTION & CONTROL™

**NSK**

# BEARINGS FOR THE PETROCHEMICAL INDUSTRY



---

As one of the world's leading manufacturers of rolling bearings, linear technology components and steering systems, we can be found on almost every continent – with production facilities, sales offices and technology centres – because our customers appreciate short decision-making channels, prompt deliveries and local service.



### The NSK company

---

NSK commenced operations as the first Japanese manufacturer of rolling bearings back in 1916. Ever since, we have been continuously expanding and improving not only our product portfolio but also our range of services for various industrial sectors. In this context, we develop technologies in the fields of rolling bearings, linear systems, components for the automotive industry and mechatronic systems. Our research and production facilities in Europe, Americas and Asia are linked together in a global technology

network. Here we concentrate not only on the development of new technologies, but also on the continuous optimisation of quality – at every process stage.

Among other things, our research activities include product design, simulation applications using a variety of analytical systems and the development of different steels and lubricants for rolling bearings.

## Partnership based on trust – and trust based on quality

Total Quality by NSK: The synergies of our global network of NSK Technology Centres. Just one example of how we meet our requirements for high quality.

NSK is one of the leading companies with a long tradition in patent applications for machine parts. In our worldwide research centres, we not only concentrate on the development of new technologies, but also on the continual

improvement of quality based on the integrated technology platform of tribology, material technology, analysis and mechatronics.



---

Keeping your production equipment at  
the highest level of performance and reliability



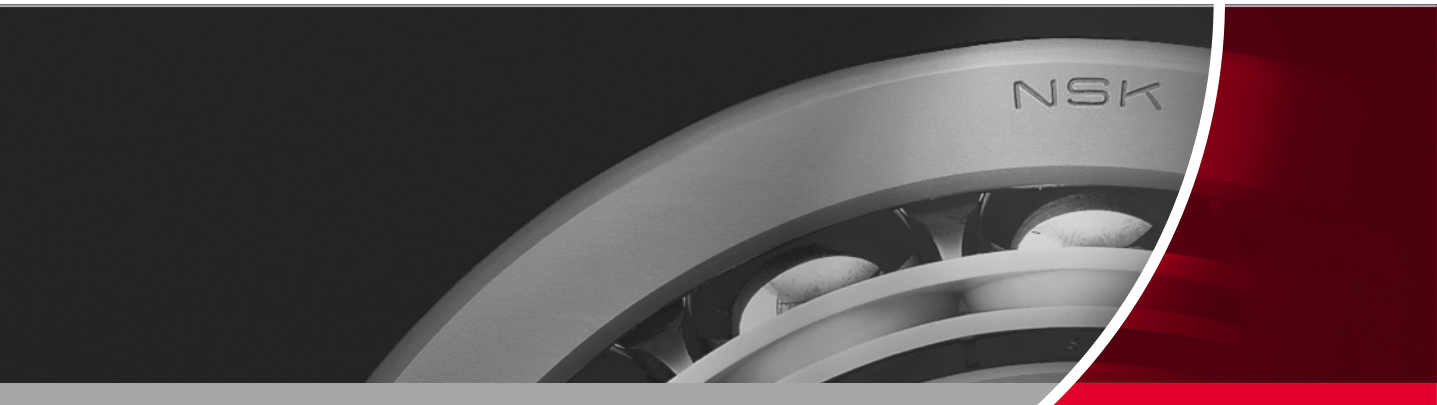

Companies in the Petrochemical Industry need bearings that are able to increase mean time between failures (MTBF), minimise costly downtime and reduce loss of productivity. The machine components used in this sector – such as pumps, compressors, electric motors and ventilators – are extremely sensitive. As a global supplier to the world’s leading manufacturers in these industries, NSK has the experience and expertise to help its customers manage their costs and improve production efficiency.

Please find below examples of strategic equipment where you cannot accept bearing premature failures:

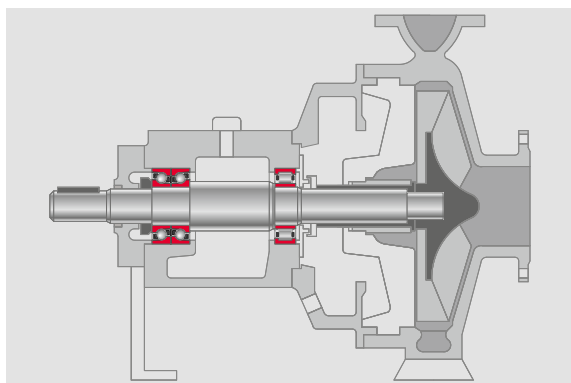

### Centrifugal Pumps

#### Bearing Selection

- › Cylindrical Roller Bearings
- › Angular Contact Ball Bearings
- › Double Row Angular Contact Ball Bearings
- › Deep Groove Ball Bearings – special: HR series

#### Operating Conditions

- › Speed: 1500 rpm – 3000 rpm
- › Axial & radial loads

#### Bearing Requirements

- › Long life under high axial loads
- › Small axial free play

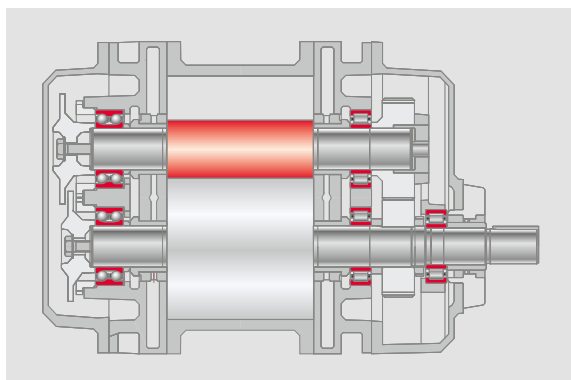

### Roots Blower

#### Bearing Selection

- › Cylindrical Roller Bearings
- › Angular Contact Ball Bearings
- › Double Row Angular Contact Ball Bearings
- › Deep Groove Ball Bearings

#### Operating Conditions

- › Oil-free
- › Medium to high temperature
- › Vibration

#### Bearing Requirements

- › Long life
- › Heat resistance

# Explicit requests demand precise solutions

NSK is introducing a new series of bearings in order to increase mean time between failures (MTBF). This new series enables you to reduce your operating costs by improving bearing life for very sensitive equipment such as pumps.

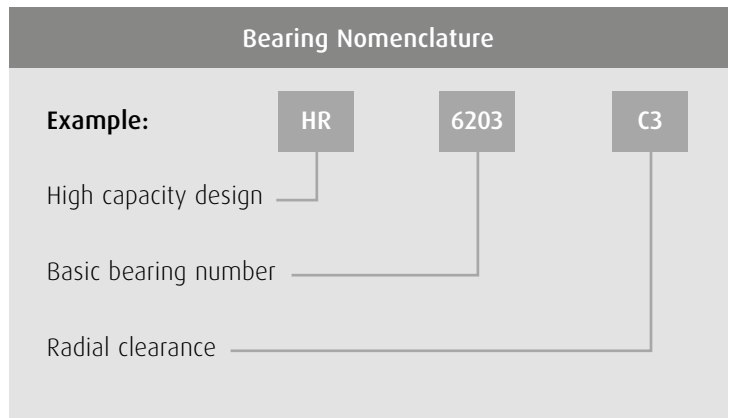
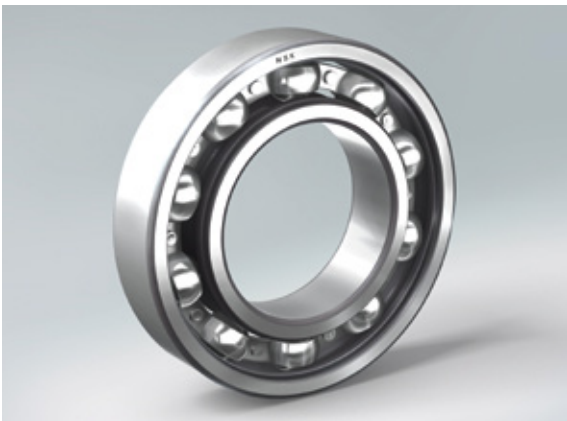

**Bigger rolling elements:**  
load capacity increased

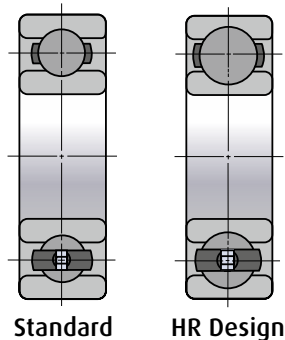

## High-capacity deep-groove ball bearings

The HR series of high-capacity deep-groove ball bearings features a special internal design, allowing for larger rolling elements than standard deep-groove ball bearings. However, the external dimensions remain the same, according to ISO standards. These new bearings increase dynamic load ratings by 7% to 19% (depending on size), resulting in a 22% to 68% increase in ISO life. In this way, the HR series can improve the life of your machine, minimising the costly downtime you would otherwise face.

# Cost Saving – Petrochemical Refinery

## Using HR deep-groove ball bearings saves a refinery more than €27,000 a year

A petrochemical refinery plant was experiencing recurrent failures of a cylindrical roller bearing in a critical centrifugal pump. The transition from belt drive to direct drive on the pump led to unexplained bearing failure, resulting in costly downtime. Thanks to the implementation of our Asset Improvement Programme (AIP), the problem was analysed and identified.

In addition to providing high-quality products, it is also our duty to help make your machines more reliable by providing a range of technical, consultancy, analytical and commercial value-adding services.

The NSK engineers investigated the application conditions and found the reasons behind this recurrent bearing failure. They discovered that switching from a belt-driven to a direct-driven configuration drastically reduced the radial load on the bearing, which led to rollers slipping on the inner raceway. The bearing was successfully replaced with an NSK HR deep-groove ball bearing, as the minimum radial load was lower than those of the cylindrical roller bearing and the load capacities were sufficient to match the application requirements.

Thanks to the AIP programme, machine reliability at the refinery improved and our customer saved more than €27,000 per annum.

**COST SAVINGS**  
PETROCHEMICAL REFINERY

SKOTON & CONTROL™  
**NSK**

---

**History**

A petrochemical refinery plant was experiencing recurrent failures of a cylindrical roller bearing (N217) in a critical centrifugal pump. Transition from belt drive to direct drive of the pump led to the unexplained bearing failure, resulting in costly downtime.



**Actual Cost Saving**

**€ 27,845**

**Cost Saving Description**

- Long Life
- Material Substitution
- Reduced Maintenance
- Technical Support

**Corrective Measures**

NSK investigated the application conditions and the failed bearing and found the solution. The switch from belt-driven to direct-driven configuration has drastically reduced the radial load on the N217 which has led to rollers slipping on the inner raceway. Bearing N217 was successfully replaced by a deep groove ball bearing 6307.

OLD DESIGN		Cost p.a.	NSK DESIGN		Cost p.a.
	Old bearing costs	€ 150		New bearing costs	€ 25
	3 breakdown x 2 liters x 6 hours x € 20/hour	€ 720			
	3 breakdown x 6 hours x € 1,500/hour	€ 27,000			
<b>Total Cost Per Year € 27,870</b>			<b>Total Cost Per Year € 25</b>		

[www.nsk.europa.com](http://www.nsk.europa.com)

(S-4-2012) 

---

# Innovative products for increased productivity

---

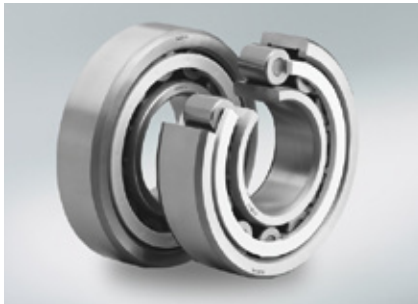

## **Cylindrical Roller Bearings with L-PPS Cage**

- › Optimised internal design
- › L-PPS cage with superior heat and wear resistance
- › High load capacity
- › Improved lubricant flow



## **NSK HPS Angular Contact Ball Bearings with L-PPS Cage**

- › High load capacity
- › High rotating speed
- › High precision: P5 (ISO Class 5) running accuracy
- › Universal facing
- › Tight axial clearance/preload tolerance
- › 40 degree Contact Angle
- › L-PPS cage with superior heat and wear resistance

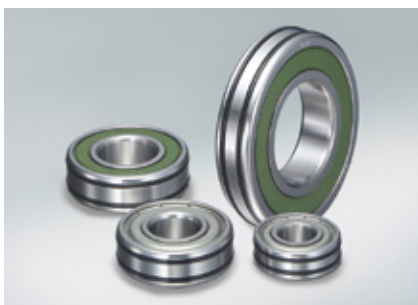

## **Creep-Free Bearings**

- › Prevents creeping
- › No special machining of the housing is required
- › Easy to assemble
- › Reusable housing



#### **LNG Pump Bearings**

- › Can run immersed in Liquefied Natural gas, up to  $-162^{\circ}\text{C}$  at speeds up to 3600Rpm
- › Self-lubricating cage
- › Inner & outer rings in stainless steel
- › Rolling elements in stainless steel
- › Maintenance intervals extended

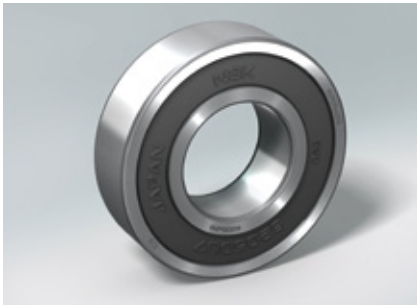

#### **Sealed Single Row Deep Groove Ball Bearings for High Temperature**

- › Viton™ seals
- › Can run up to  $150^{\circ}\text{C}$
- › Low noise level
- › Stabilised rings



#### **High Capacity Deep Groove Ball Bearings (HR series)**

- › Special internal design
- › Bigger rolling elements
- › Increased dynamic load rating
- › Increased life in operation
- › Interchangeable with the standard range

This is a non-exhaustive overview of NSK bearings used in the Petrochemical Industry. If you require additional bearings, please contact NSK.

# Standard Bearing Range



## NSK HPS Angular Contact Ball Bearings with Brass Cage

- › Optimised internal design
- › High strength ball guided brass cage
- › High running accuracy P5 (ISO Class 5)
- › High load ratings
- › Universal facing in standard
- › 40 degree Contact Angle



## Single Row Cylindrical Roller Bearings with Brass Cage, Steel Cage or Polyamide Cage

- › Pressed steel cage series: EW
- › Polyamide cage series: ET
- › Machined brass cage series: EM



## Double Row Angular Contact Ball Bearings

Available ranges: 3200 – 3300 / 5200 – 5300 Series

- › Steel or polyamide cage
- › Open
- › Shielded ZZ or ZZ
- › Sealed DDU or 2RS



## Single Row Radial Ball Bearings

Available ranges: 600, 6800, 6900, 16000, 16100, 6000, 6200, 6300, 6400 Series

- › Standard and special applications
- › Steel, brass or polyamide cage
- › Low noise
- › Full sealing options
- › Wide range of greases
- › Standard or special steels



### **Tapered Roller Bearing**

- › Inch & metric sizes
- › Standard steel / carburised steel / HTF treatment
- › Custom-made sets with spacers



### **NSK HPS Spherical Roller Bearings**

- › High load capacity
- › High limiting speed
- › High strength cage (steel or brass)
- › Low noise and vibration



### **Plummer blocks**

To ensure effective sealing, plummer blocks are available with a variety of special seal options and end covers. The benefits include a facility for easy mounting and dismounting of pre-assembled shafts.

# Getting to the heart of service: the AIP Value Cycle

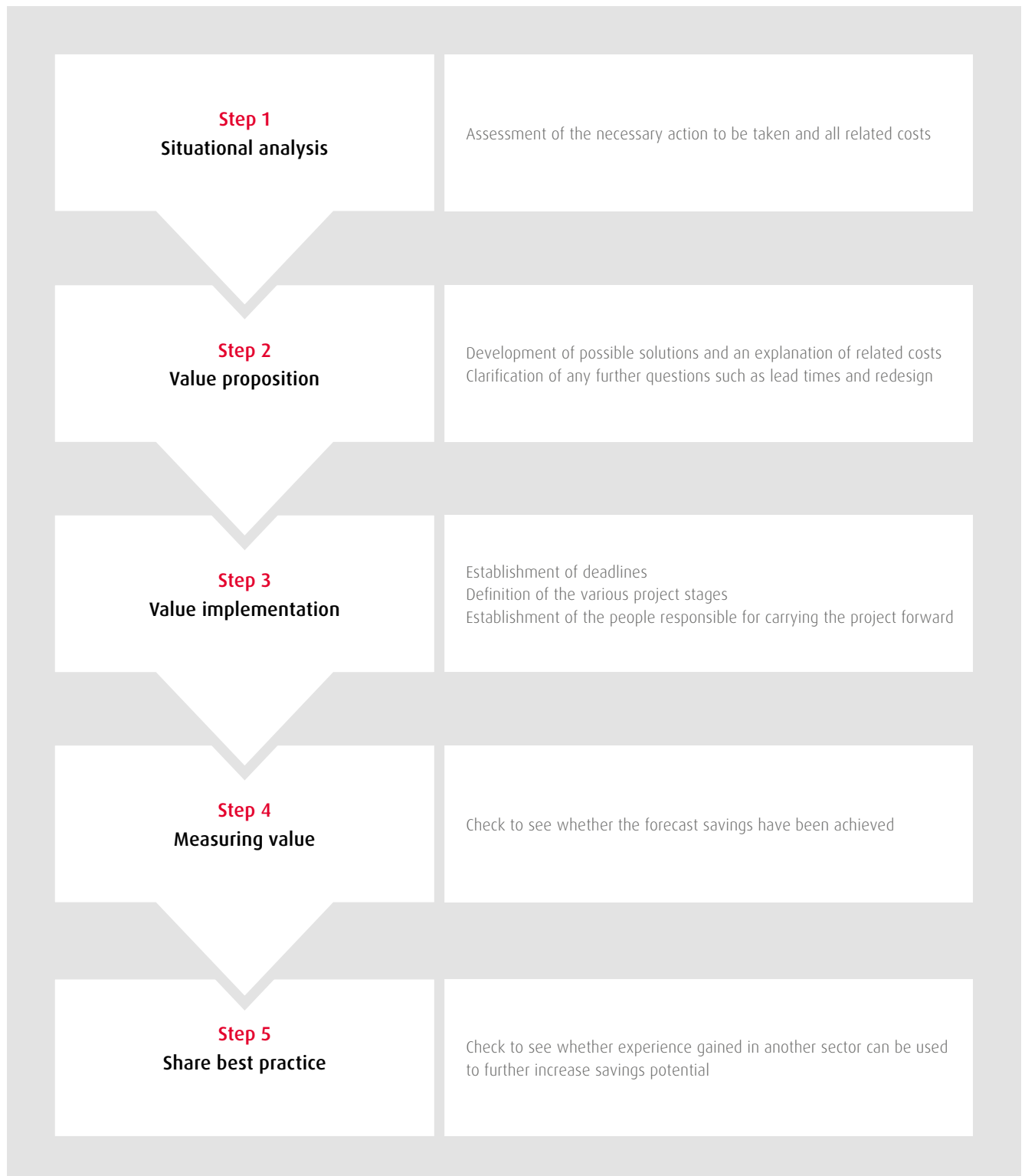



To be the manufacturer and distributor of good products is not enough nowadays; we believe that being an active partner with a broad spectrum of services to support our clients is more important. Our highly experienced staff are on the ground and ready to work with you directly to find individual solutions for smooth, efficient and profitable production processes in your company.

**Increased profitability thanks to AIP**

Less machine and plant downtime. Cost reduction without affecting quality. With AIP, a well-proven asset improvement programme, we help you to recognise, and act on, profitability potential. The programme combines existing knowledge in your field of competence and your corporate processes with the latest NSK technical knowledge.

Starting with a situational analysis, we compile a structured catalogue of measures together with you and assist you with its implementation. A Measuring Value check ensures that you achieve the sought-after advantages inside the agreed time frame.

Additionally, we offer training courses, carry out specialised service and repair services in our NSK Service Centres, and continually expand our online applications on our secure client site.



**NSK Service Spectrum**

Technical Support	Training Courses	Analytical Services	Value Added Services
Application Reviews	Introduction to Bearing Technology (Parts 1 & 2)	Failure Mode Analysis	NSK Cost Down Approach
Engineering Support	Best Practice Fitting & Removal of Bearings (Sections 1 & 2)	Material Analysis	Maintenance Schedules
Machine Design Consultancy	Bearing Diagnostics	OEM Part Conversion	Site Surveys
Bearing Surveys	Application of Bearings	Standardisation & Rationalisation	Maintenance Tool Audits
Diagnostic & Vibration Analysis	Sector Specific		Super Precision Service Package
	Food & Beverage Pumps & Compressors Quarry, Mining & Construction	Paper, Metals & Steel Machine Tool, Railway	





## European NSK Sales Offices

### UK

NSK UK Ltd.  
Northern Road, Newark  
Nottinghamshire NG24 2JF  
Tel. +44 (0) 1636 605123  
Fax +44 (0) 1636 602775  
info-uk@nsk.com

### France

NSK France S.A.S.  
Quartier de l'Europe  
2, Rue Georges Guynemer  
78283 Guyancourt Cedex  
Tel. +33 (0) 1 30573939  
Fax +33 (0) 1 30570001  
info-fr@nsk.com

### Germany

NSK Deutschland GmbH  
Harkortstraße 15  
40880 Ratingen  
Tel. +49 (0) 2102 4810  
Fax +49 (0) 2102 4812290  
info-de@nsk.com

### Italy

NSK Italia S.p.A.  
Via Garibaldi 215 - C.P. 103  
20024 Garbagnate  
Milanese (MI)  
Tel. +39 02 995191  
Fax +39 02 99025778  
info-it@nsk.com

### Norway

**Nordic Sales Office**  
NSK Europe Norwegian Branch NUF  
Østre Kullerød 5  
N-3241 Sandefjord  
Tel. +47 33 293160  
Fax +47 33 429002  
info-n@nsk.com

### Poland & CEE

NSK Polska Sp. z o.o.  
Warsaw Branch  
Ul. Migdałowa 4/73  
02-796 Warszawa  
Tel. +48 22 6451525  
Fax +48 22 6451529  
info-pl@nsk.com

### Spain

NSK Spain, S.A.  
C/ Tarragona, 161 Cuerpo Bajo  
2ª Planta, 08014 Barcelona  
Tel. +34 93 2892763  
Fax +34 93 4335776  
info-es@nsk.com

### Sweden

NSK Sweden Office  
Karolinen Företagscenter  
Våxnäsgratan 10  
SE-65340 Karlstad  
Tel. +46 5410 3545  
Fax +46 5410 3544  
info-de@nsk.com

### Turkey

NSK Rulmanları Orta Doğu Tic. Ltd. Şti  
19 Mayıs Mah. Atatürk Cad.  
Ulya Engin İş Merkezi No: 68 Kat. 6  
P.K.: 34734 - Kozyatağı - İstanbul  
Tel. +90 216 3550398  
Fax +90 216 3550399  
turkey@nsk.com

